

Instructions



Ground Fault Protection Systems

Performance Testing

Performance Testing Ground Fault Protection Systems

CONTENTS

DESCRIPTION	PAGE
General Information	2
Checklist for G.F. Testing	3
Test Methods	3,4
Test Equipment	4
Notes on Testing	4
Test Diagrams for Systems with G.F. Relays	5 to 12
Test Diagrams for Systems with Integral G.F.P.	13 to 16
Test Record Forms	17 to 20

The Circuit Diagrams included in this manual are for illustration of typical applications and are not intended as constructional information. Although reasonable care has been taken in their preparation to assure their technical correctness, no responsibility is assumed by the General Electric Company for any consequences of their use.

The devices and arrangements disclosed herein may be covered by patents of General Electric Company or others. Neither the disclosure of any information herein nor the sale of devices by General Electric Company conveys any license under patent claims covering combinations of devices with other devices or elements.

In the absence of any express written agreement to the contrary, General Electric Company assumes no liability for patent infringement arising out of any use of the devices or elements by any purchaser of devices or others.

PURPOSE

The purpose of this publication is to provide instructions for testing ground fault protection (GFP) systems in General Electric low-voltage equipment. These instructions are for use with equipment built by the Distribution Equipment Division, in accordance with the National Electrical Code, Section 230-95.

NEC 230-95(c) reads as follows:

(c) The ground fault protection system shall be performance tested when first installed. The test shall be conducted in accordance with approved instructions which shall be provided with the equipment. A written record of this test shall be made and shall be available to the authority having jurisdiction.

INSTRUCTIONS APPLICABLE TO

EQUIPMENT

Switchboards:
Type AV & Powerbreak

Low-Voltage Switchgear:
AKD-6 & AKD-8

CIRCUIT BREAKERS

Insulated-Case & Molded Case Breakers with VersaTrip, SelecTrip or MicroVersaTrip Trip.

LV Power Circuit Breakers
Type AKR with -SST or Micro VersaTrip Trip.

FUSIBLE SWITCH

Type HPC/HPR High Pressure Contact Switch with Integral Ground Fault Tripping

GROUND FAULT RELAYS & SENSORS

Ground-Break System or similar ground fault relays and sensors (CT's) used to trip any circuit breaker or switch with a shunt trip.

TESTING BY QUALIFIED PERSONNEL

Performance testing of the ground fault protection system should be undertaken only by qualified personnel. Particularly in the tests requiring the use of a high-current test set, it is usually necessary to obtain the services of a qualified testing organization. General Electric's Installation and Service Engineering organization and the Apparatus Service Shops are qualified and equipped to provide this testing service.

Checklist For Ground Fault Performance Testing

PROBLEMS THAT MAY BE ENCOUNTERED THAT CAN PREVENT PROPER GFP OPERATION

HOW TO CHECK FOR THIS CONDITION

<p>1. On 3-phase 4-wire systems, the neutral conductor should not have additional grounding connections made downstream from the main bonding jumper which must be located in the service entrance section. (Refer to NEC 250-23). This condition may cause loss of sensitivity in sensing ground fault current.</p>	<p>By visual inspection.</p> <p>By measurement of resistance between neutral conductor and ground bus.</p> <p>In the high-current tests this condition may be the cause if it takes over 150% of G.F. current setting to initiate tripping.</p>
<p>2. Neutral sensor in residual sensor arrangements or with integral G.F. trip breaker may be installed with incorrect polarity with respect to the associated phase sensors. This will cause false tripping by reading balanced load current as imbalanced and interpreting the error signal as a fault situation.</p> <p>3. Neutral conductor in a load circuit must pass through a zero-sequence sensor in the same direction as the phase conductors. Unbalanced signals cause false tripping.</p> <p>4. When a given circuit is monitored by a zero-sequence sensor, none of the conductors shall be omitted from passing through the sensor. Unbalanced signals cause false tripping.</p>	<p>By visual inspection.</p> <p>In the high-current testing the "no-trip" tests will detect this condition.</p>
<p>5. An equipment bonding or grounding conductor must not be passed through the window of a G.F. sensor. This will cause cancellation of error signals, and will prevent G.F. tripping when it is needed.</p>	<p>Inspect load cables and grounding connections between conduits and the switchboard ground bus. The grounding connections must not pass through a zero-sequence sensor, with phase and neutral wires.</p>
<p>6. The ground fault protection may be rendered inoperable by damaged wiring or devices, blown or missing control fuses, or lack of tripping power when supplied from a remote source.</p>	<p>If the high-current tests do not produce expected tripping, check for control power at transformers, at fuses, and at relays.</p>

Testing Methods

GENERAL

There are two alternate test methods for evaluating ground fault protection (GFP) systems — by using simulated fault current or by high-current primary injection. Both test methods are applicable to ground-fault relay systems, but only the high-current primary injection method can be used to test a system with integral ground-fault trip circuit breakers.

If it is acceptable to the local inspection authorities, ground fault relay systems may be tested by the simulated fault current testing method combined with a thorough visual inspection. Otherwise, it will be necessary to use the high-current primary injection test method.

GROUND FAULT PROTECTION TESTING WITH SIMULATED FAULT CURRENT

In the simulated fault current method, a simulated fault current is generated by a coil around a window-type sensor or by means of a separate test winding in the sensor. When the monitor panel sends a small current through the test winding, it produces a secondary current in the sensor which the relay responds to as if it were caused by a primary current of 1600 amperes.

In an equivalent method which can be used with any window-type sensor supplying a ground fault relay, a number of turns of wire are wrapped around the sensor core, such as twenty turns of #14 wire. A current of approximately 125 percent of the pickup setting of the relay divided by the number of turns is passed through the wire to simulate the ground-fault current. By setting the relay pickup to the low end of the range, the test current may be kept to a minimum.

Testing with simulated fault current provides a means of demonstrating the operation of the sensor, relay and shunt trip and the adequacy of the control power supply. In addition to these items, the GFP system must be checked to confirm that neutral ground points are located correctly with respect to sensors, that sensor polarities are correct when several are connected in parallel, and that conductors which pass through a sensor window all run in the same direction. If done thoroughly by a qualified person, a visual inspection can confirm that these items have been taken care of correctly.

The importance of supplementing simulated fault current testing with an adequate inspection is emphasized when one realizes that the first five items on the Checklist (see above) are problems that can NOT be detected by simulated fault current testing alone.

Testing Methods

Continued

GROUND FAULT PROTECTION TESTING BY HIGH-CURRENT PRIMARY INJECTION

The high-current injection test method may be used to test GFP systems with either ground fault relays or integral ground fault trips on circuit breakers. With relays, it is an alternative to simulated fault-current testing supplemented by inspection. We recommend it as the best way to test the performance of GFP systems with relays.

Integral ground fault protection in circuit breakers can be system-tested only by using the high-current injection test method. The internal electronics of these breakers can be checked out with test sets such as Cat. No. TAK-TS2, which is used with AKR-SST/ECS trips and with VersaTrip Mod. 2 or TVTS1 used with MicroVersaTrip. These sets are not suitable for making a *system* test, however.

High-current testing of GFP systems consists of injecting full-scale current into the equipment phase and neutral conductors to duplicate the flow of ground fault current under various conditions. The testing equipment required includes a high-current supply capable of delivering up to 1000 amperes or more at 2.5 volts, or similar. By using the lower ground fault current pickup settings on relays and breakers or switches, the current required to trip can be kept to a minimum, such as 300 or 400 amperes or less. If inspection authorities require tests at full GFP setting, a current supply capable of delivering 1200 amperes or more may be needed.

Connect the current supply as shown in the diagrams, using flexible welding cable such as No. 2 AWG. Also connect jumpers between the points indicated in the tables accompanying the diagrams.

GROUND FAULT PROTECTION IN THREE-WIRE EQUIPMENT

Ground fault protection can be provided for 3-wire and 4-wire equipment fed from a solidly grounded 4-wire supply, wye or delta. NEC Article 250-23(b) requires that whenever a service is derived from a grounded neutral system, the grounded neutral conductor must be brought into the service entrance equipment, and bonded to the equipment enclosure and ground bus, even if the grounded conductor is not needed for the load supplied by the service. This is required to provide a low-impedance ground fault current return path to the neutral to assure operation of the over-current device.

Test Diagrams For Systems With Ground Fault Relays

PAGE 5 THROUGH PAGE 12

FIGURE	DESCRIPTION
1	Main Breaker with G.F. Relay and Ground Return Sensor
2	Main Breaker with G.F. Relay and Zero-Sequence Sensor Arrangement
3	Main Breaker with G.F. Relay and Residual Sensor Arrangement
4	Feeder Breaker with G.F. Relay and Zero-Sequence Sensor Arrangement
5	Ground Fault Relay Protection on Normal and Emergency Main Breakers Interlocked for Automatic Throwover
6	Ground Fault Relay Protection on Normal and Emergency Main Breakers with Automatic Transfer Switch (3-pole)
7	Double-ended Substation — (Transformers not individually grounded) Single-point Ground and G.F. Relays
8	Double-ended Equipment — (both sources grounded) Modified Differential Scheme with G.F. relays.

Test Notes:

1. All tests are for 3-phase, 4-wire unless noted as 3-phase 3-wire.
2. Notes on diagrams referring to tripping at G.F. setting are intended to imply nominal values. Consistent tripping may require 125% of pickup settings, and good time-delay figures may be obtained only at 150% and higher.
3. **WARNING** In all the illustrations the source transformer(s) must be deenergized when applying and using the test current.
4. A temporary source of control power (usually 120 VAC) will be needed for operation of Ground-Break relays and shunt trip devices.
5. For information on the Ground-Break System, refer to publications GEI-86126 & GET-2964.

Test Diagrams

FIGURE 1
Main Breaker with G.F. Relay and Ground-Return Sensor

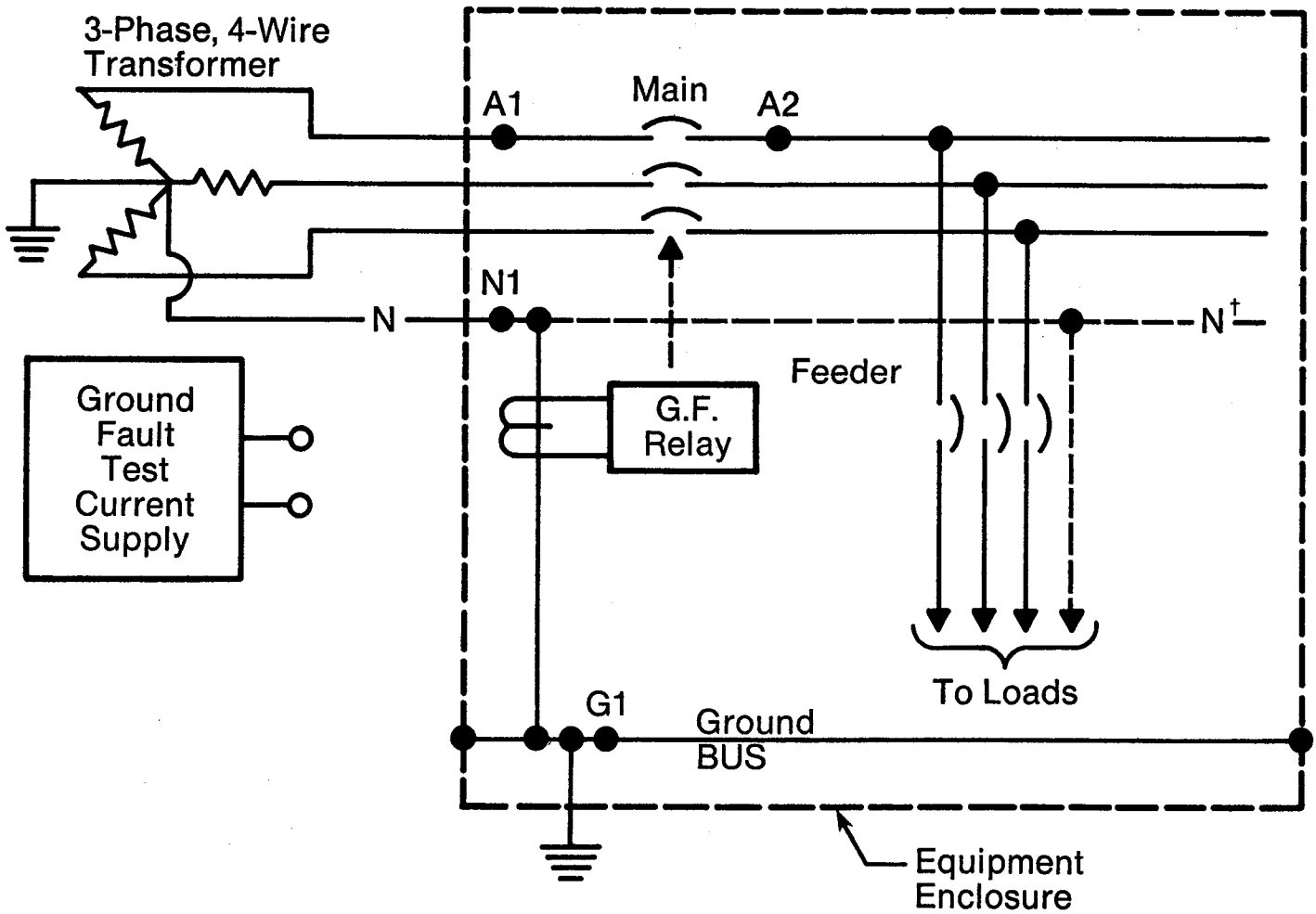

Test No.	Connect Test Current Supply to Points	Connect Jumper between Points	Results Expected	Comments
1-1	A1 and N1	A2-G1	Main breaker should trip	Confirms continuity of ground path from ground bus to neutral

† In 3-wire equipment the load neutral is not furnished.

FIGURE 2
Main Breaker with G.F. Relay and Zero-Sequence
Sensor Arrangement

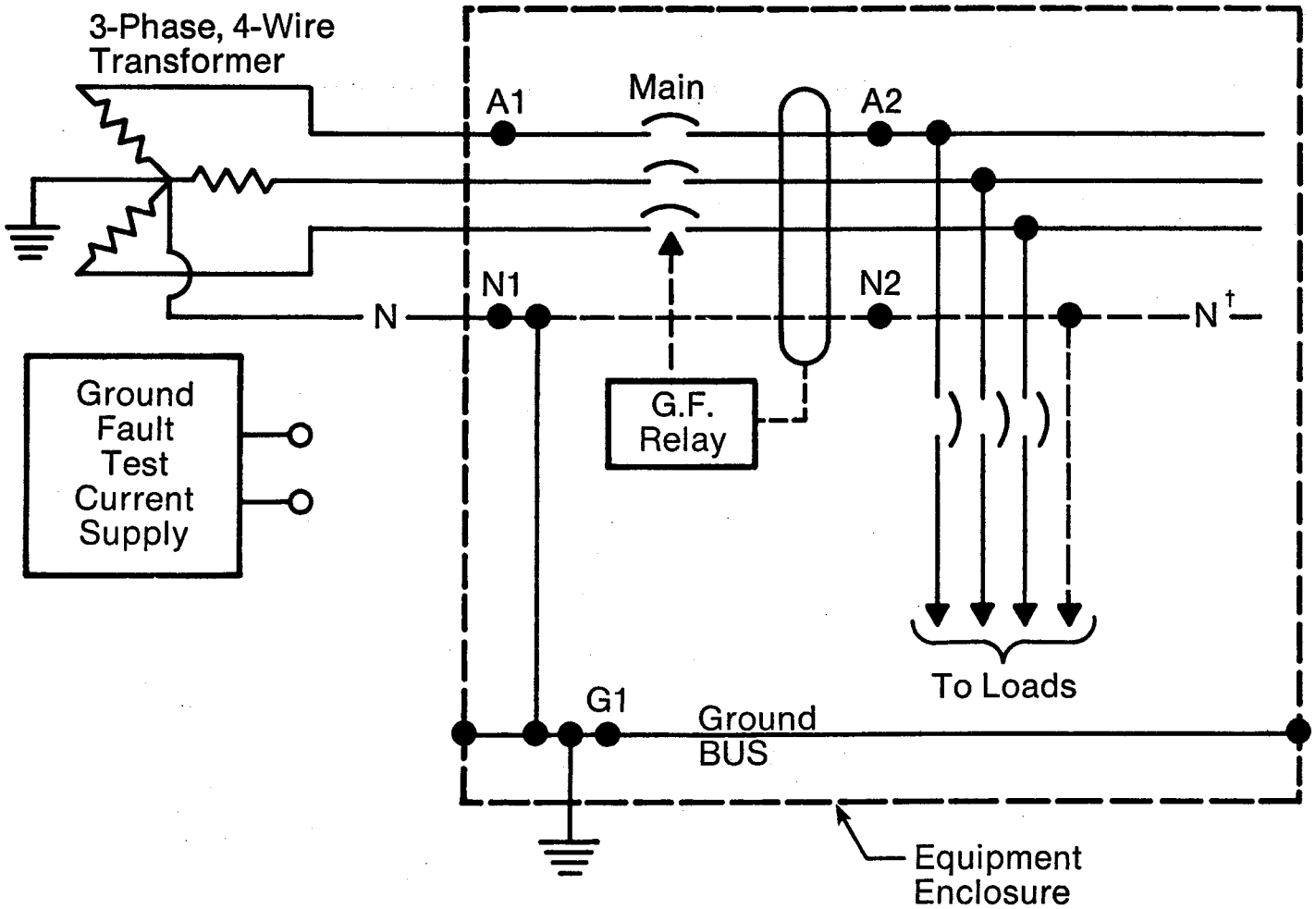

Test No.	Connect Test Current Supply to Points	Connect Jumper between Points	Results Expected	Comments
2-1	A1 and N1	A2-N2	Main breaker should <i>not</i> trip	Confirms that neutral and phase conductors go through sensor and in same direction
2-2	A1 and N1	A2-G1	Main breaker should trip	Confirms continuity of ground path from ground bus to neutral

NOTE: It is not necessary to repeat the tests for each phase if a visual inspection confirms that all phases go through the sensor window.

† In 3-wire equipment the load neutral is not furnished. Omit Test 2-1.

FIGURE 3
Main Breaker with G.F. Relay and Residual
Sensor Arrangement

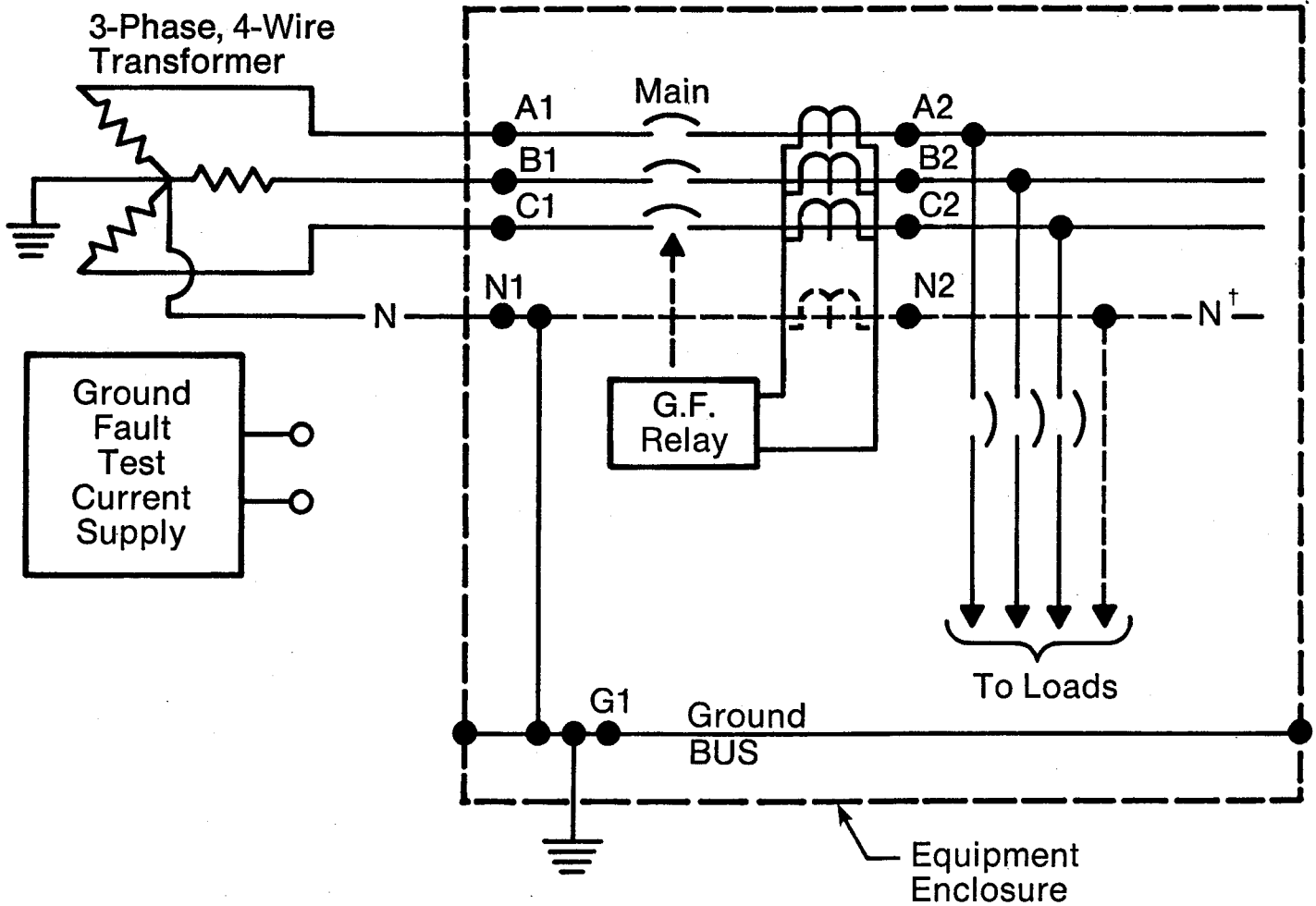

Test No.	Connect Test Current Supply to Points	Connect Jumper between Points	Results Expected	Comments
3-1	A1 and N1 B1 and N1 C1 and N1	A2-N2 B2-N2 C2-N2	Breaker should <i>not</i> trip.	Confirms correct polarity of sensor connections.
3-2	A1 and N1 B1 and N1 C1 and N1	A2-G1 B2-G1 C2-G1	Breaker should trip.	Confirms continuity of ground path from ground bus to neutral.

† In 3-wire equipment, the load neutral and neutral sensor are not furnished. Omit Test 3-1.

FIGURE 4
Feeder Breaker with G.F. Relay and Zero-Sequence Sensor Arrangement

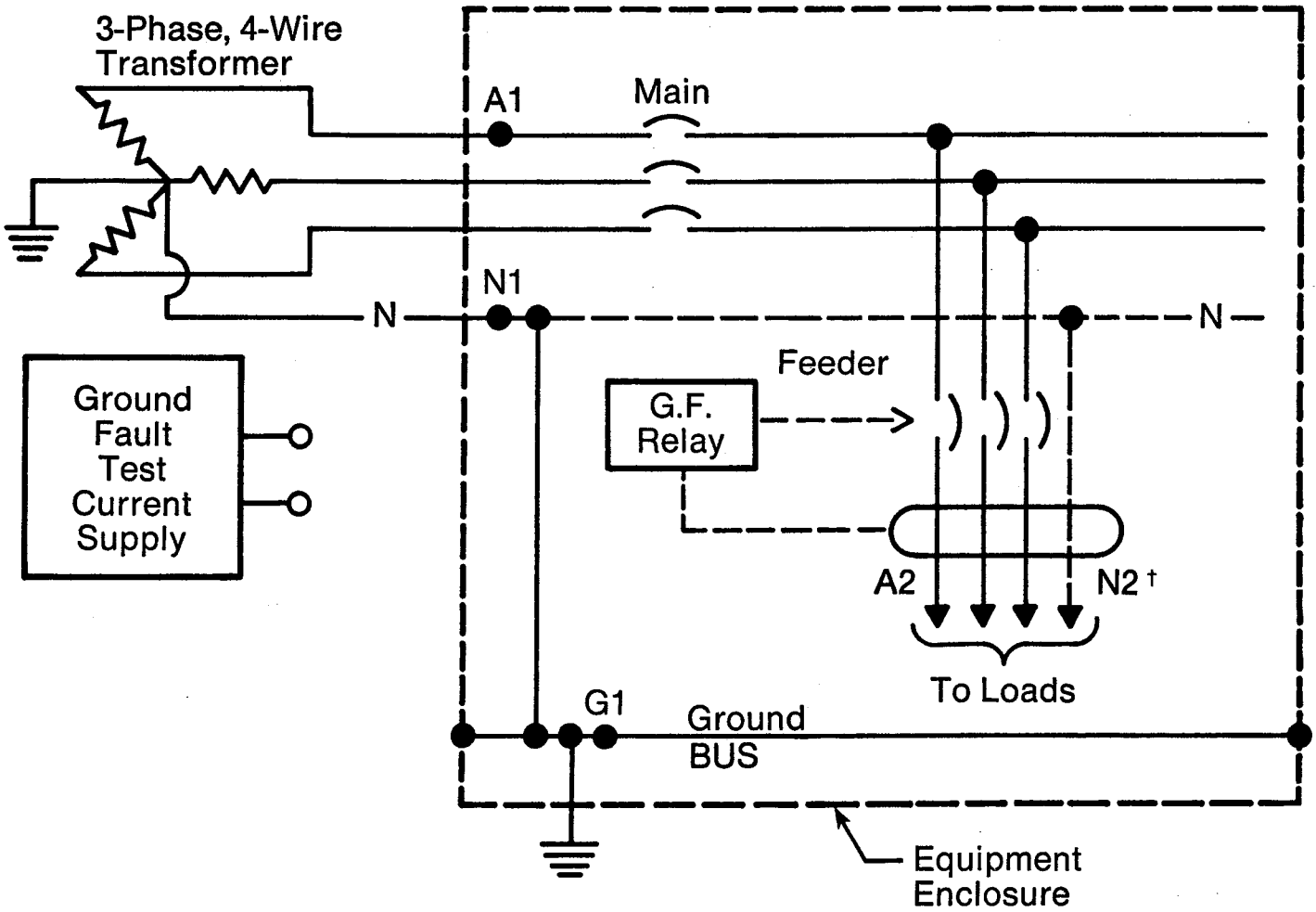

Test No.	Connect Test Current Supply to Points	Connect Jumper between Points	Results Expected	Comments
4-1	A1 and N1	A2-N2	Breaker should <i>not</i> trip.	Confirms correct polarity of sensor connections.
4-2	A1 and N1	A2-G1	Breaker should trip.	Confirms continuity of ground path from ground bus to neutral.

NOTE: It is not necessary to repeat the tests for each phase if a visual inspection confirms that all phases go through the sensor window.

† On 3-wire feeders, the neutral conductor is not furnished. Omit Test 4-1.

FIGURE 5

Ground Fault Relay Protection on Normal and Emergency Main Breakers Interlocked for Automatic Throwover on 3-Phase 4-Wire System

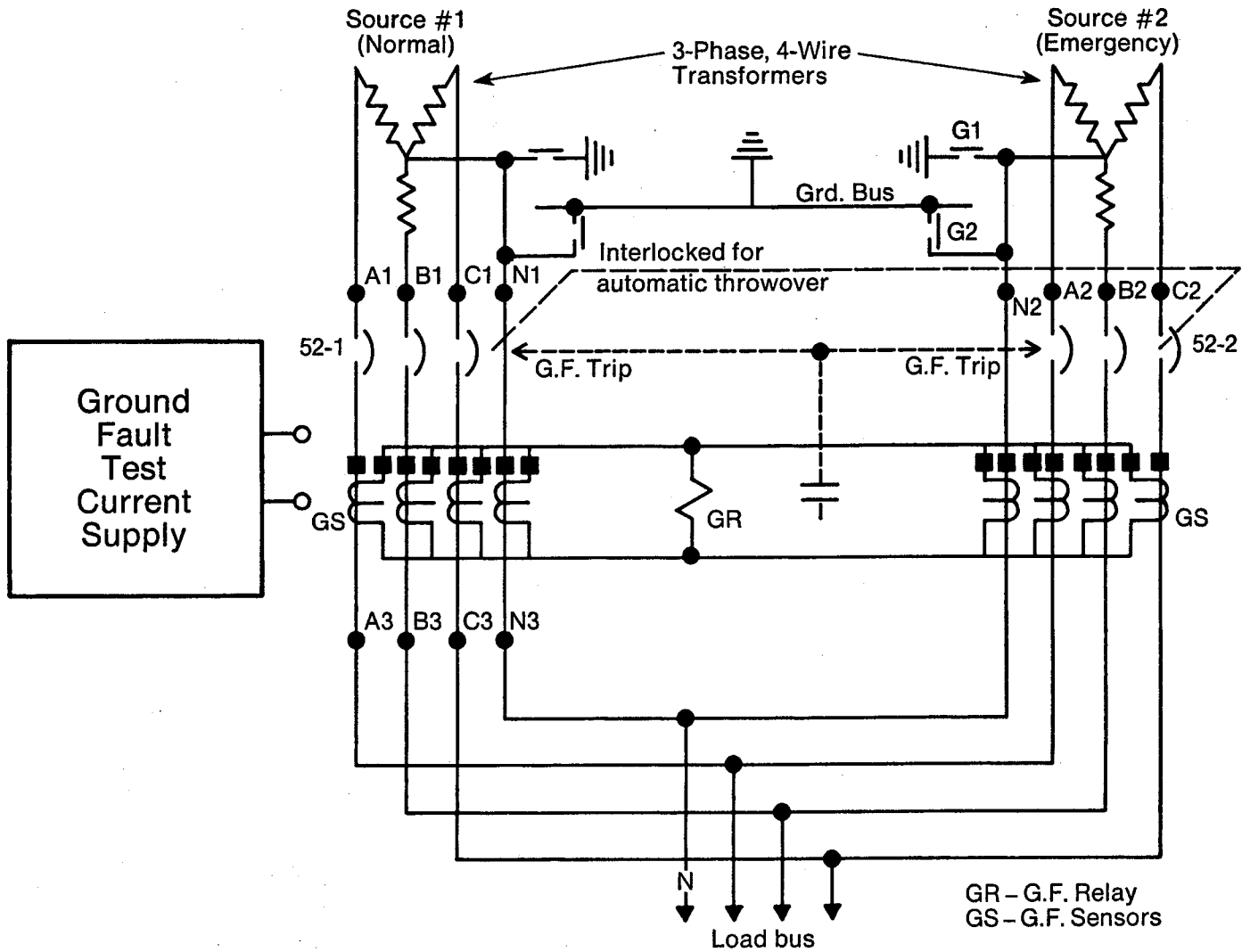

Test No.	Connect Test Current Supply to Points	Connect Jumper between Points	During the Test Disconnect Ground from Neutral at Points	Results Expected	Comments
5-1	A1 and N1 B1 and N1 C1 and N1	A3-N3 B3-N3 C3-N3	G1 and G2 G1 and G2 G1 and G2	Breaker 52-1 should not trip.	Confirms correct polarity of sensor connections.
5-2	A2 and N2 B2 and N2 C2 and N2	A3-N3 B3-N3 C3-N3	G1 and G2 G1 and G2 G1 and G2	Breaker 52-2 should not trip.	
5-3	A2 and N2 B2 and N2 C2 and N2	A3-N1 B3-N1 C3-N1	G1 and G2 G1 and G2 G1 and G2	Breaker 52-2 should trip.	Confirms operation when ground return path is through neutral from most distant ground.
5-4	A1 and N1 B1 and N1 C1 and N1	A3-N2 B3-N2 C3-N2	G1 and G2 G1 and G2 G1 and G2	Breaker 52-1 should trip.	

FIGURE 6

Ground Fault Relay Protection on Normal and Emergency Main Breakers with Automatic Transfer Switch (3-Pole) on 3-Phase 4-Wire System

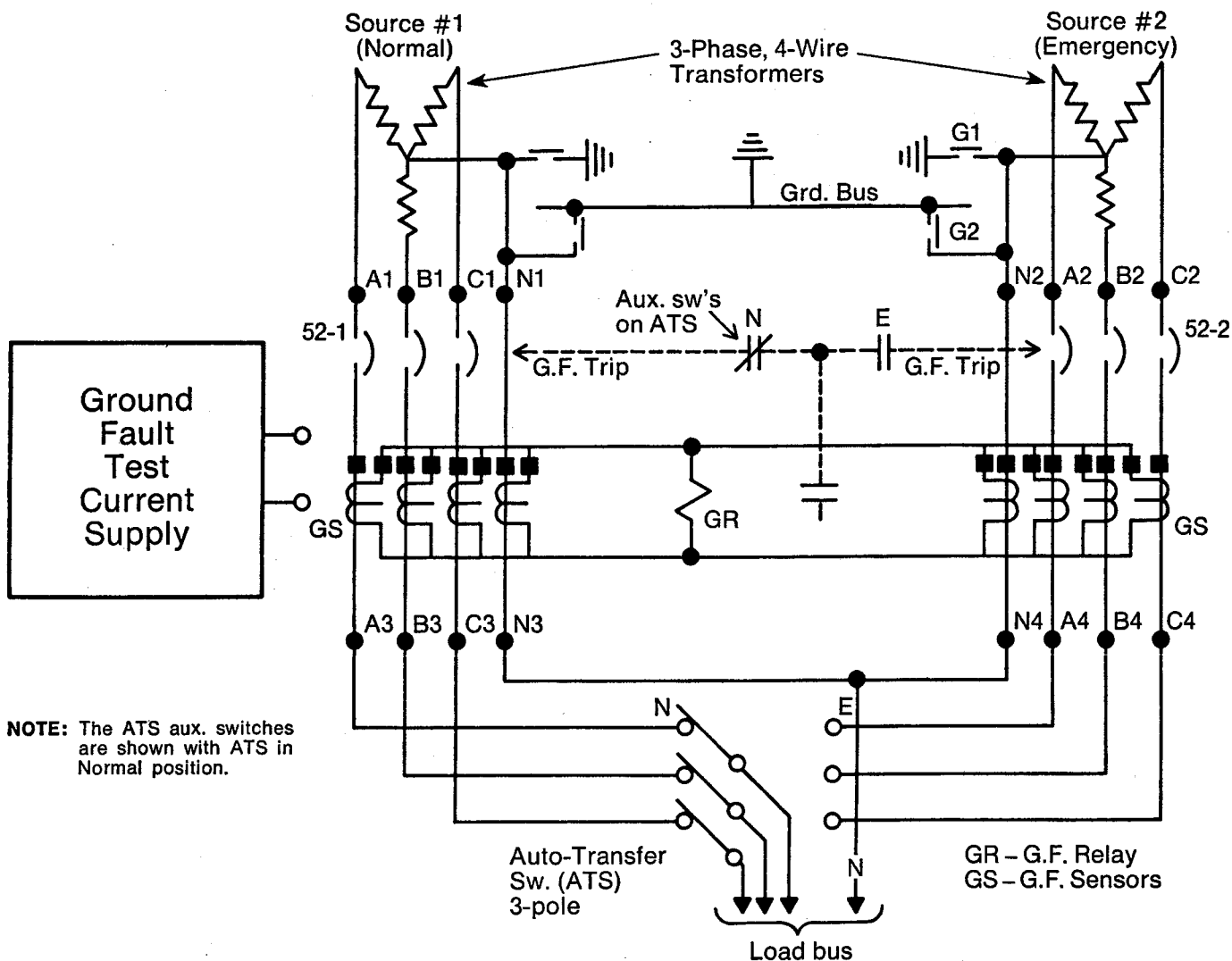

NOTE: The ATS aux. switches are shown with ATS in Normal position.

GR – G.F. Relay
GS – G.F. Sensors

Test No.	Transfer Switch Position	Connect Test Current Supply to Points	Connect Jumper between Points	During the Test Disconnect Ground from Neutral at these Points	Results Expected	Comments
6-1	N N N	A1 and N1 B1 and N1 C1 and N1	A3-N3 B3-N3 C3-N3	G1 and G2 G1 and G2 G1 and G2	Breaker 52-1 should not trip.	Confirms correct polarity of sensor connections.
6-2	E E E	A2 and N2 B2 and N2 C2 and N2	A4-N4 B4-N4 C4-N4	G1 and G2 G1 and G2 G1 and G2	Breaker 52-2 should not trip.	
6-3	E E E	A2 and N2 B2 and N2 C2 and N2	A4-N1 B4-N1 C4-N1	G1 and G2 G1 and G2 G1 and G2	Breaker 52-2 should trip.	Confirms operation when ground return path is through neutral from most distant ground.
6-4	N N N	A1 and N1 B1 and N1 C1 and N1	A3-N2 B3-N2 C3-N2	G1 and G2 G1 and G2 G1 and G2	Breaker 52-1 should trip.	

FIGURE 7

Double-Ended Substation (Transformers Not Individually Grounded) with Single-Point Ground and G.F. Relays on 3-Phase 4-Wire System

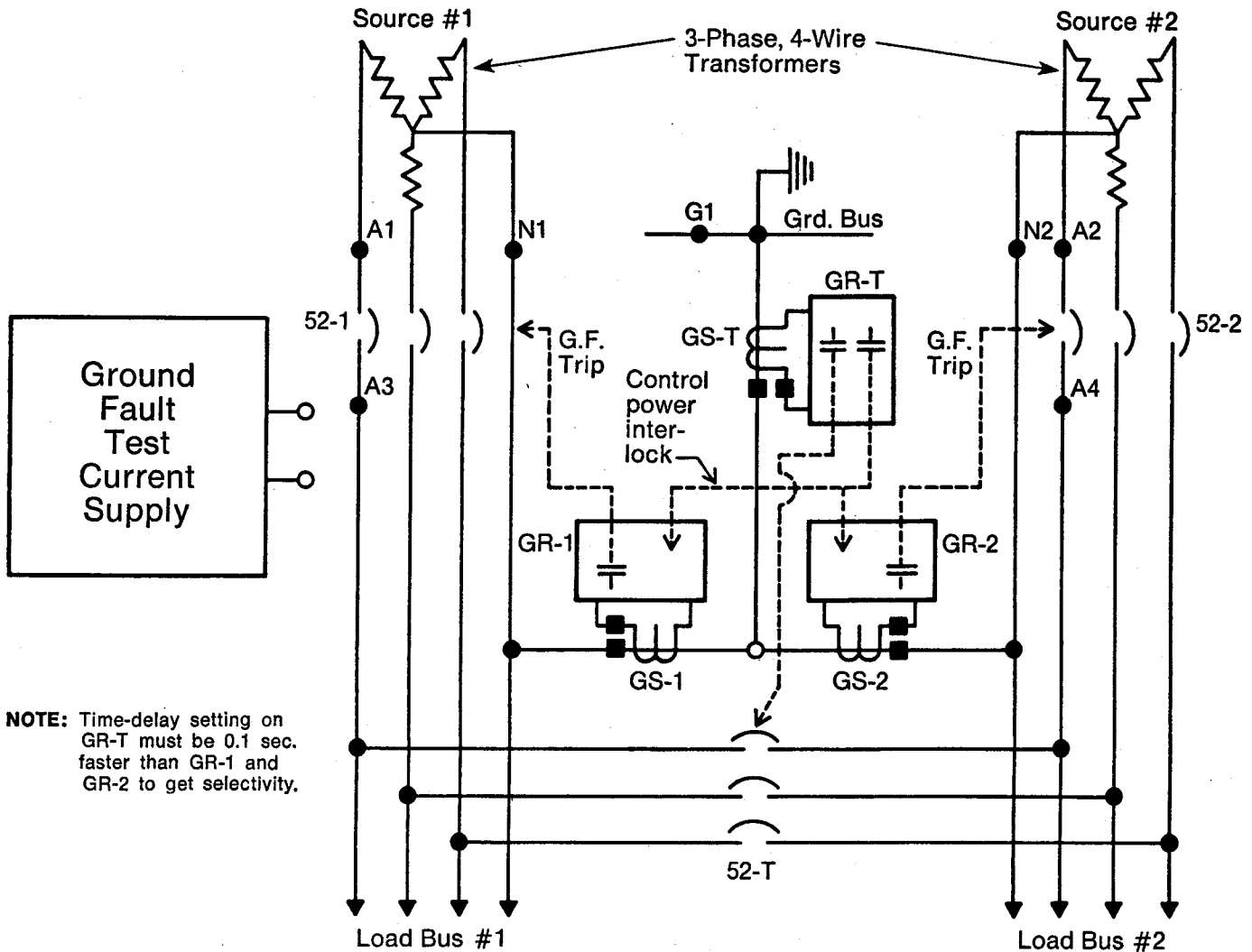

NOTE: Time-delay setting on GR-T must be 0.1 sec. faster than GR-1 and GR-2 to get selectivity.

Test No.	Connect Test Current Supply to Points	Connect Jumper between Points	Breakers Open or Closed			Results Expected	Comments
			52-1	52-T	52-2		
7-1	A1 and N1	A3-G1	c	o	c	Breaker 52-1 should trip.	52-1 trips for a G.F. on load bus #1.
7-2	A2 and N2	A4-G1	c	o	c	Breaker 52-2 should trip.	52-2 trips for a G.F. on load bus #2.
7-3	A2 and N2	A3-G1	o	c	c	Breaker 52-T should trip and Breaker 52-2 should not trip (see note).	52-T trips for a G.F. on load bus #1, fed from source #2.
7-4	A1 and N1	A4-G1	c	c	o	Breaker 52-T should trip and Breaker 52-1 should not trip (see note).	52-T trips for a G.F. on load bus #2, fed from source #1.

FIGURE 8

Double-Ended Equipment (Both Sources Grounded) using Modified Differential Scheme with G.F. Relays on 3-Phase 4-Wire System

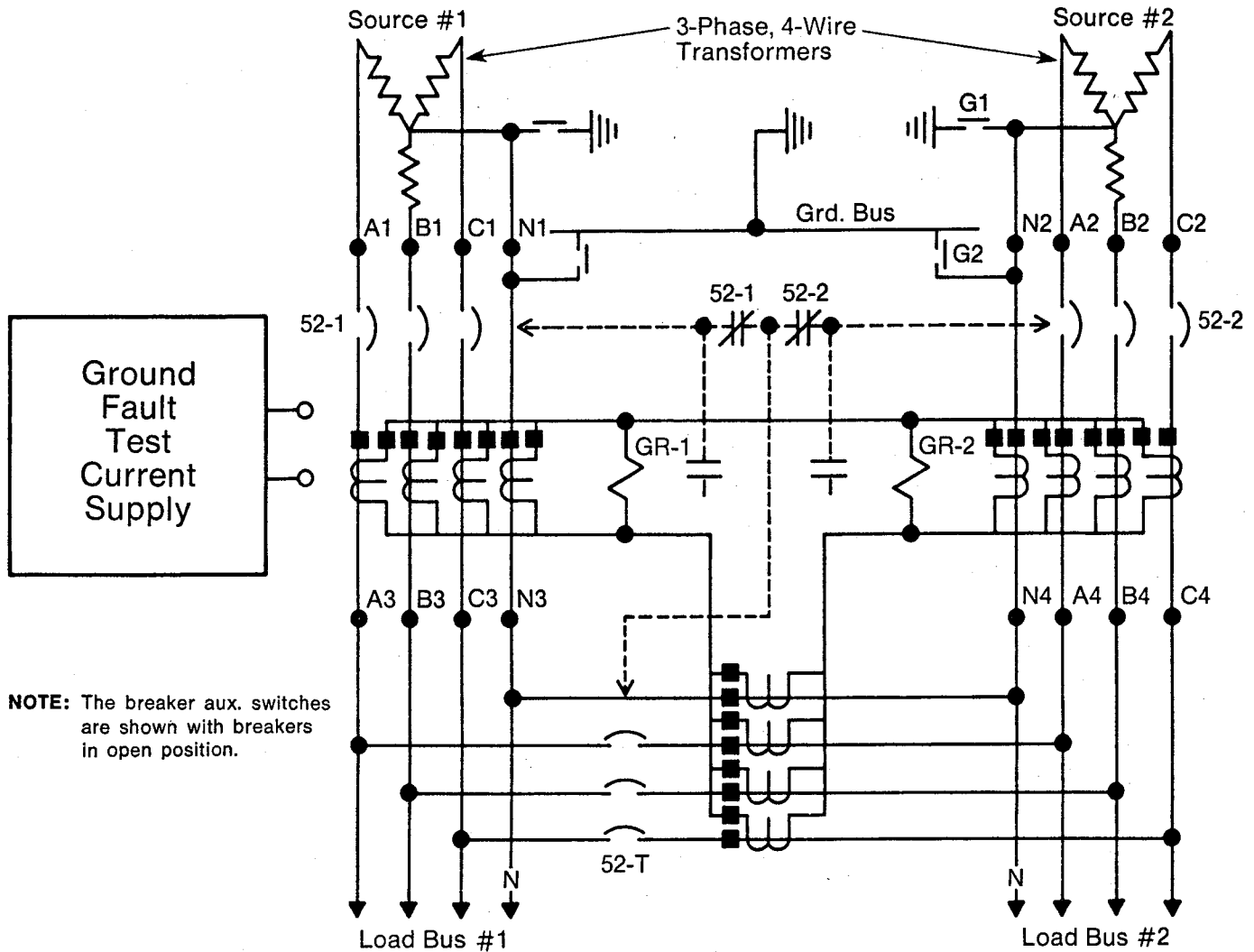

NOTE: The breaker aux. switches are shown with breakers in open position.

Test No.	Connect Test Current Supply to Points	Connect Jumper between Points	During the Test. Disconnect Ground from Neutral at Points	Breakers Open or Closed			Results Expected	Comments
				52-1	52-T	52-2		
8-1	A1 and N1 B1 and N1 C1 and N1	A4-N4 B4-N4 C4-N4	G1 and G2 G1 and G2 G1 and G2	c c c	c c c	o o o	Breakers 52-1 and 52-T should not trip.	Confirms correct polarity of sensor connections.
8-2	A2 and N2 B2 and N2 C2 and N2	A4-N4 B4-N4 C4-N4	G1 and G2 G1 and G2 G1 and G2	o o o	c c c	c c c	Breaker 52-2 should not trip.	
8-3	A2 and N2 B2 and N2 C2 and N2	A4-N1 B4-N1 C4-N1	G1 and G2 G1 and G2 G1 and G2	o o o	c c c	c c c	Breaker 52-2 should trip.	52-2 trips for a G.F. on load bus #2.
8-4	A1 and N1 B1 and N1 C1 and N1	A3-N2 B3-N2 C3-N2	G1 and G2 G1 and G2 G1 and G2	c c c	c c c	o o o	Breaker 52-1 should trip.	52-1 trips for a G.F. on load bus #1.
8-5	A1 and N1 B1 and N1 C1 and N1	A4-N2 B4-N2 C4-N2	G1 and G2 G1 and G2 G1 and G2	c c c	c c c	o o o	Breaker 52-T should trip.	52-T trips for a G.F. on load bus #2.

Test Diagrams For Systems With Integral Ground Fault Protection

PAGE 13 THROUGH PAGE 16

FIGURE	DESCRIPTION
9	Neutral Sensor Polarity Markings
10	Main Breaker with Integral GFP
11	Feeder Breaker with Integral GFP
12	Integral GFP on Main and Tie Breakers of Double-ended Equipment — 3-Phase, 4-Wire

NEUTRAL SENSOR POLARITY MARKINGS

In the accompanying integral ground fault protection circuit diagrams the neutral sensors are depicted using conventional current transformer symbols. The equivalent polarity markings for VersaTrip, SelecTrip, SST and Micro VersaTrip integral trip sensors are shown in the figure below.

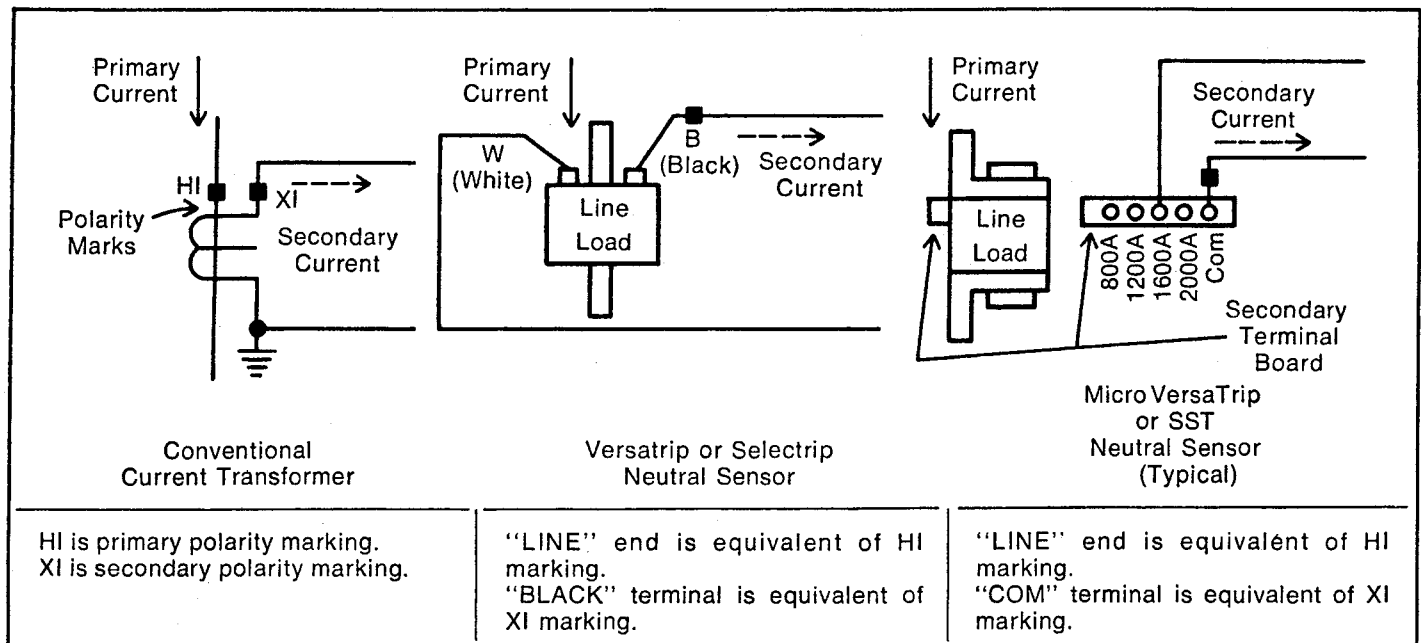

FIGURE 9

This diagram shows the equivalent polarity markings for neutral sensors that are not marked like conventional current transformers.

Note:

WARNING In all the illustrations the source transformer(s) must be deenergized when applying and using the test current.

Test Diagrams

FIGURE 10
Main Breaker with Integral Ground-Fault Protection —
3-Phase, 4-Wire

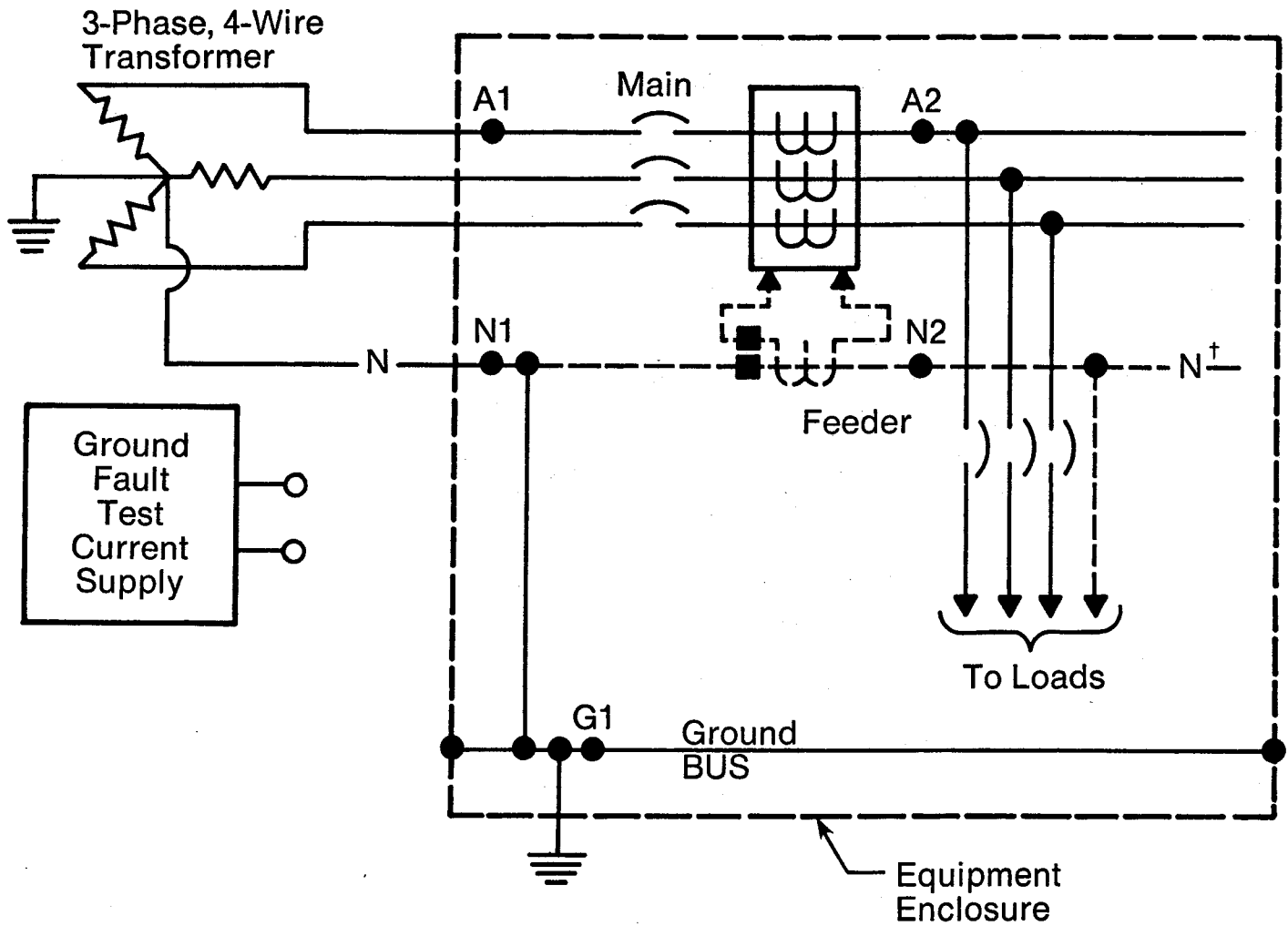

Test No.	Connect Test Current Supply to Points	Connect Jumper between Points	Results Expected	Comments
10-1	A1 and N1	A2-N2	Breaker should <i>not</i> trip.	This confirms that polarity and ampere rating of the neutral sensor match those of the phase sensors in the breaker.
10-2	A1 and N1	A2-G1	Breaker should trip at G.F. setting.	Confirms continuity of ground path from ground bus to neutral.

† In 3-wire equipment the load neutral is not furnished. Omit Test 10-1.

FIGURE 11
Feeder Breaker with Integral Ground-Fault Protection —
3-Phase, 4-Wire

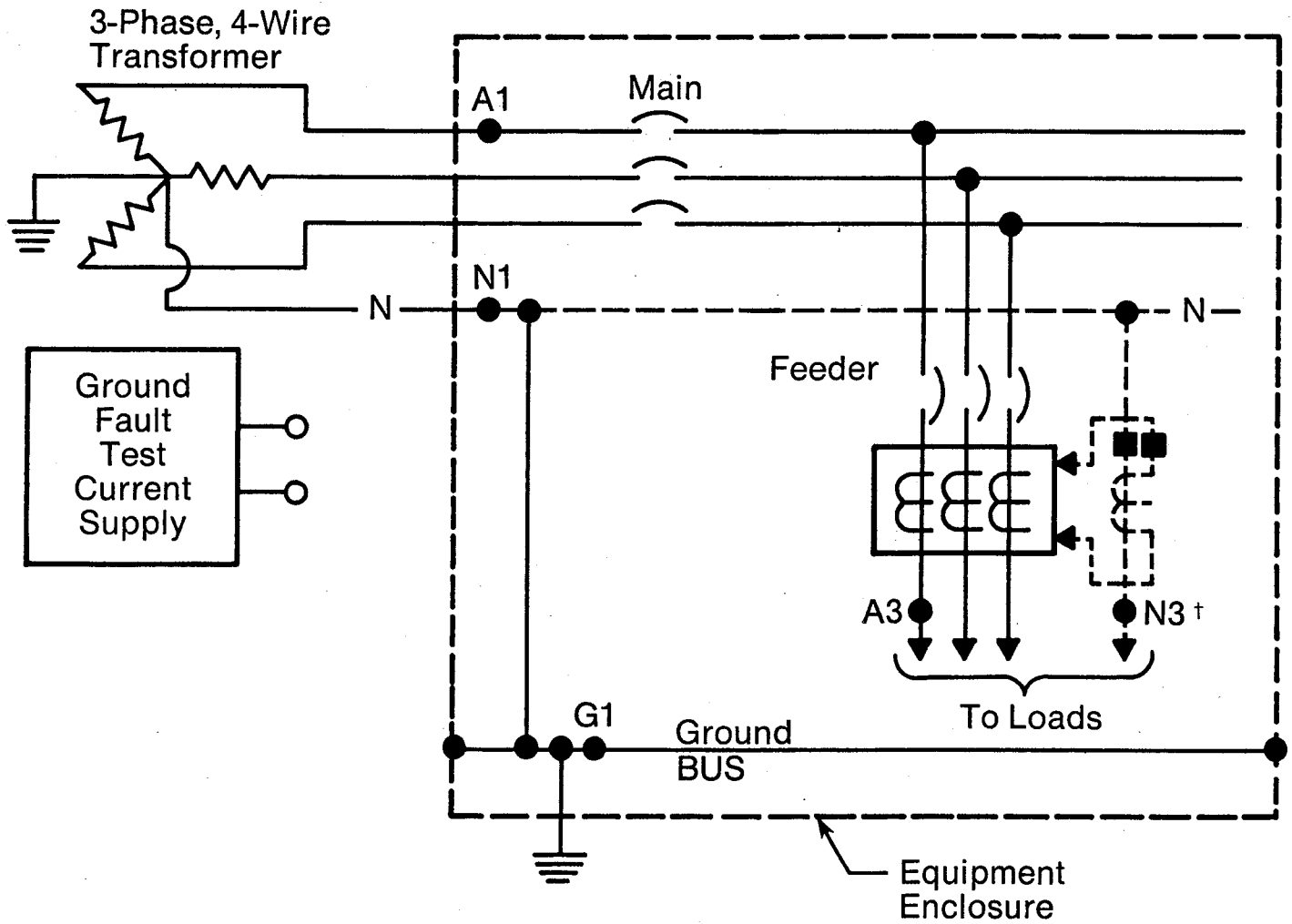

Test No.	Connect Test Current Supply to Points	Connect Jumper between Points	Results Expected	Comments
11-1	A1 and N1	A3-N3	Breaker should <i>not</i> trip.	This confirms that polarity and ampere rating of the neutral sensor match those of the phase sensors in the breaker.
11-2	A1 and N1	A3-G1	Breaker should trip at G.F. setting.	Confirms continuity of ground path from ground bus to neutral.

† On 3-wire feeders the neutral conductor and neutral sensor are not furnished. Omit Test 11-1.

FIGURE 12

Integral Ground Fault Protection on Main and Tie Breakers of Double-Ended Equipment — 3-Phase, 4-Wire

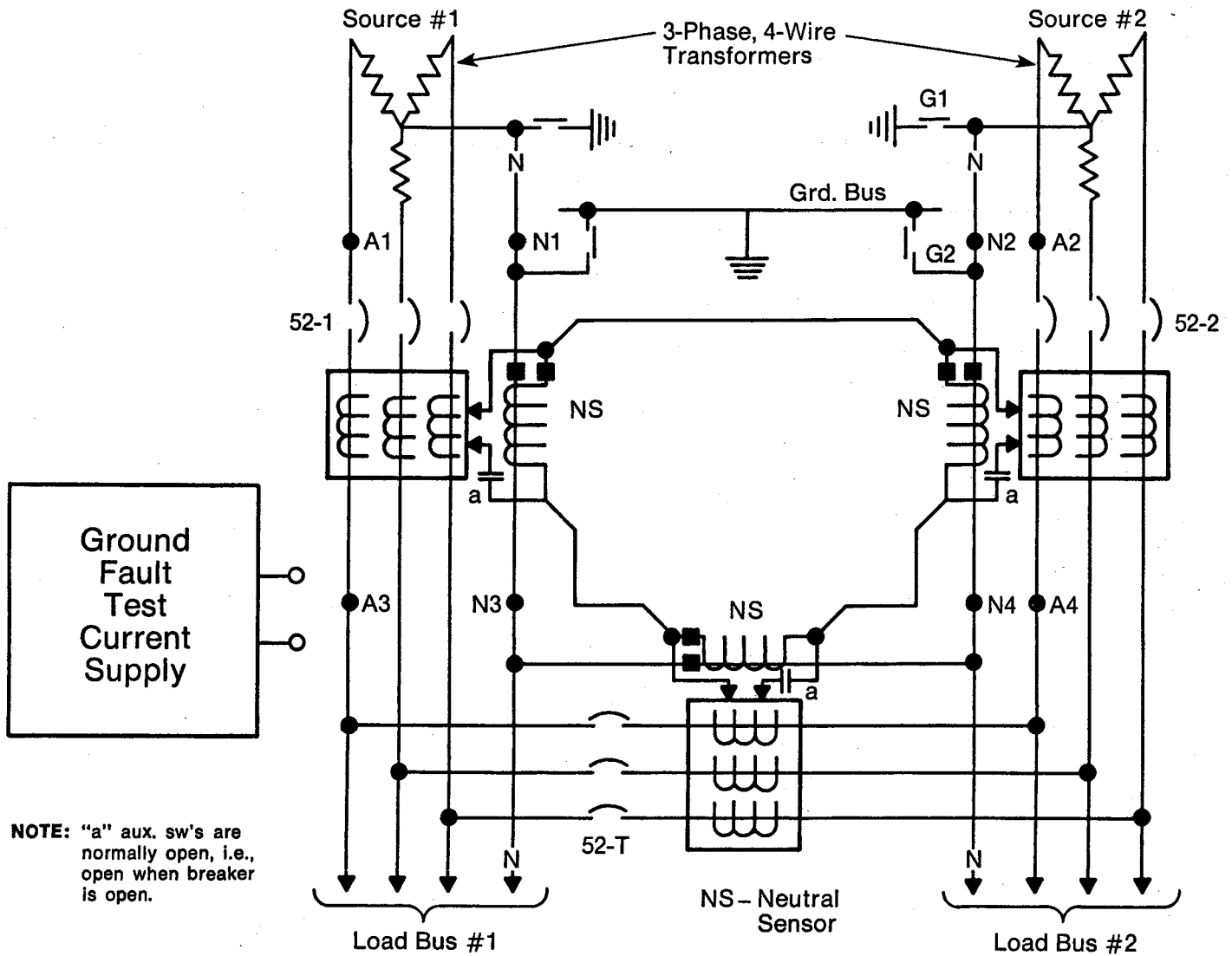

Test No.	Connect Test Current Supply to Points	Connect Jumper between Points	During the Test Disconnect Ground from Neutral at Points	Breakers Open or Closed			Results Expected	Comments
				52-1	52-T	52-2		
12-1	A1 and N1	A4-N4	G1 and G2	c	c	o	Breakers 52-1 and 52-T should not trip.	Confirms that sensor polarity is correct.
12-2	A2 and N2	A4-N4	G1 and G2	o	c	c	Breaker 52-2 should not trip.	
12-3	A2 and N2	A4-N1	G1 and G2	o	c	c	Breaker 52-2 should trip.	52-2 trips for a G.F. on load bus #2.
12-4	A1 and N1	A3-N2	G1 and G2	c	c	o	Breaker 52-1 should trip.	52-1 trips for a G.F. on load bus #1.
12-5	A1 and N1	A4-N2	G1 and G2	c	c	o	Breaker 52-T should trip.	52-T trips for a G.F. on load bus #2.

Ground Fault Protection With Ground Fault Relays PERFORMANCE TEST RECORD

This test form should be retained by those in charge of the building's electrical installation in order to be available to the authority having jurisdiction.

General Electric Order/Requisition No. _____

Customer Name _____

Location _____

Order No. _____

EQUIPMENT

- AV-Line Switchboard
 - PowerBreak Switchboard
 - AKD-6 L.V. Switchgear AKD-8 L.V. Switchgear
 - Other _____
- Rating: Volts _____ Phase _____ Wire _____
Amps. _____ Hz. _____

EQUIPMENT ARRANGEMENT

- Single-source
- Double-ended Other (explain) _____
- Unit-Substation Transformer(s) remote from equipment.

GROUND FAULT PROTECTION

Breaker (or switch) tripped by G.F. relay:
Function: Main Feeder; Circuit No. _____
Type _____ Drawout Stationary
Rating (Amps): Frame _____ Trip _____

GROUND FAULT RELAY & ACCESSORIES

Ground-break System Other (explain) _____
Relay Cat. No. _____ Pickup Range (Amps) _____
Sensor (C.T.) Cat. No. _____
Monitor Panel (if used) Cat. No. _____

SENSOR ARRANGEMENT:

- Ground-return Type
- Residual (sensor on each phase).
- Zero-sequence (all conductors thru one window).
- Double-ended: Single-Point Ground Scheme Modified-Differential Scheme

Additional Description (if needed) _____

Ground Fault Protection With Ground Fault Relays PERFORMANCE TEST RECORD

TEST RECORD

Test Number	G.F. RELAY SETTING		Test Current (Amps)	TRIPPING RESULTS	
	Pickup (Amps)	Delay (Sec.)		Bkr/Sw. Trip?	Measured Time For Bkr/Sw. to Open

CONCLUSIONS:

The test results are satisfactory. _____

The test results are not satisfactory. _____

(Explain) _____

Tests performed by: _____

Test Set Used: _____

Test Date: _____

Witnessed By: _____

Ground Fault Protection With Integral Ground Fault Trips On Circuit Breaker PERFORMANCE TEST RECORD

TEST RECORD

Test Number	Ground Fault Settings		Test Current (Amps)	Tripping Results	
	Pickup in Mult. of Sensor Rating	Time Delay Band (min/int/max)		Bkr/Sw. Trip?	Measured Time For Bkr/Sw. to Open

CONCLUSIONS:

The test results are satisfactory. _____

The test results are not satisfactory. _____

(Explain) _____

Tests performed by: _____

Test Set Used: _____

Test Date: _____

Witnessed By: _____

Notes

Notes

Notes

Outside the U.S. write Construction Equipment Export Operation
411 Theodore Fremd Ave., Rye, NY 10580
GEI-48907 0886 PSB

For further information
call or write your local
General Electric
Sales Office or . . .

General Electric
Company
41 Woodford Avenue
Plainville, CT 06062 U.S.A.

GENERAL  **ELECTRIC**